

STARPOWER

SEMICONDUCTOR™

IGBT

GD10PIK60C5S

Preliminary

Molding Type Module**600V/10A PIM in one-package**

General Description

STARPOWER IGBT Power Module provides ultra low conduction and switching loss as well as short circuit ruggedness. They are designed for the applications such as general inverters and UPS.

Features

- Low $V_{CE(sat)}$ NPT IGBT technology
- 10 μ s short circuit capability
- $V_{CE(sat)}$ with positive temperature coefficient
- Square RBSOA
- Low inductance case
- Fast & soft reverse recovery anti-parallel FWD
- Isolated copper baseplate using DBC technology



Typical Applications

- Inverter for motor drive
- AC and DC servo drive amplifier
- Uninterruptible power supply

IGBT-inverter $T_C=25^\circ\text{C}$ unless otherwise noted**Maximum Rated Values**

Symbol	Description	GD10PIK60C5S	Units
V_{CES}	Collector-Emitter Voltage @ $T_j=25^\circ\text{C}$	600	V
V_{GES}	Gate-Emitter Voltage @ $T_j=25^\circ\text{C}$	± 20	V
I_C	Collector Current @ $T_C=25^\circ\text{C}$	20	A
	@ $T_C=80^\circ\text{C}$	10	
I_{CM}	Pulsed Collector Current $t_p=1\text{ms}$	20	A
P_{tot}	Total Power Dissipation @ $T_j=150^\circ\text{C}$	82	W
T_{SC}	Short Circuit Withstand Time @ $T_j=150^\circ\text{C}$	10	μs

Off Characteristics

Symbol	Parameter	Test Conditions	Min.	Typ.	Max.	Units
$V_{(BR)CES}$	Collector-Emitter Breakdown Voltage	$T_j=25^\circ\text{C}$	600			V
I_{CES}	Collector Cut-Off Current	$V_{CE}=V_{CES}, V_{GE}=0\text{V},$ $T_j=25^\circ\text{C}$			5.0	mA
I_{GES}	Gate-Emitter Leakage Current	$V_{GE}=V_{GES}, V_{CE}=0\text{V},$ $T_j=25^\circ\text{C}$			400	nA

On Characteristics

Symbol	Parameter	Test Conditions	Min.	Typ.	Max.	Units
$V_{GE(th)}$	Gate-Emitter Threshold Voltage	$I_C=250\mu\text{A}, V_{CE}=V_{GE},$ $T_j=25^\circ\text{C}$	3.5	4.5	5.5	V
$V_{CE(sat)}$	Collector to Emitter Saturation Voltage	$I_C=10\text{A}, V_{GE}=15\text{V},$ $T_j=25^\circ\text{C}$		1.80	2.25	V
		$I_C=10\text{A}, V_{GE}=15\text{V},$ $T_j=150^\circ\text{C}$		2.20		

Switching Characteristics

Symbol	Parameter	Test Conditions	Min.	Typ.	Max.	Units	
Q_G	Gate charge	$V_{CC}=400\text{V}, I_C=10\text{A},$ $V_{GE}=15\text{V}$		38		nC	
$t_{d(on)}$	Turn-On Delay Time	$V_{CC}=400\text{V}, I_C=10\text{A},$ $R_G=47\Omega, V_{GE}=15\text{V},$ $T_j=25^\circ\text{C}$		30		ns	
t_r	Rise Time			20		ns	
$t_{d(off)}$	Turn-Off Delay Time			230		ns	
t_f	Fall Time			23		ns	
E_{on}	Turn-On Switching Loss				0.14		mJ
E_{off}	Turn-Off Switching Loss				0.25		mJ

$t_{d(on)}$	Turn-On Delay Time	$V_{CC}=400V, I_C=10A,$ $R_G=47\Omega, V_{GE}=15V,$ $T_J=150^\circ C$	30		ns
t_r	Rise Time		20		ns
$t_{d(off)}$	Turn-Off Delay Time		250		ns
t_f	Fall Time		26		ns
E_{on}	Turn-On Switching Loss		0.23		mJ
E_{off}	Turn-Off Switching Loss		0.35		mJ
C_{ies}	Input Capacitance	$V_{CE}=30V, f=1Mhz,$ $V_{GE}=0V$	620		pF
C_{oes}	Output Capacitance		62		pF
C_{res}	Reverse Transfer Capacitance		22		pF
I_{SC}	SC Data	$T_P \leq 10\mu s, V_{GE}=15V,$ $T_J=125^\circ C, V_{CC}=360V,$ $V_{CEM} \leq 600V$		TBD	A

DIODE-inverter $T_C=25^\circ C$ unless otherwise noted

Maximum Rated Values

Symbol	Description	GD10PIK60C5S	Units
V_{RRM}	Repetitive Peak Reverse Voltage @ $T_J=25^\circ C$	600	V
I_F	DC Forward Current @ $T_C=80^\circ C$	10	A
I_{FRM}	Repetitive Peak Forward Current $t_p=1ms$	20	A

Characteristics Values

Symbol	Parameter	Test Conditions	Min.	Typ.	Max.	Units
V_F	Diode Forward Voltage	$I_F=10A, V_{GE}=0V$	$T_J=25^\circ C$	1.20	1.60	V
			$T_J=125^\circ C$	1.25		
t_r	Reverse Recovery Time	$V_R=600V,$	$T_J=25^\circ C$	/		ns
			$T_J=125^\circ C$	90		
I_{RM}	Peak Reverse Recovery Current	$I_F=10A,$ $R_G=47\Omega,$	$T_J=25^\circ C$	/		A
			$T_J=125^\circ C$	19		
E_{rec}	Reverse Recovery Energy	$V_{GE}=-15V$	$T_J=25^\circ C$	/		mJ
			$T_J=125^\circ C$	0.25		

DIODE-rectifier $T_C=25^\circ\text{C}$ unless otherwise noted**Maximum Rated Values**

Symbol	Description	GD10PIK60C5S	Units
V_{RRM}	Repetitive Peak Reverse Voltage @ $T_j=25^\circ\text{C}$	1600	V
$I_{F(AV)}$	Average On-state Current @ $T_C=100^\circ\text{C}$	12	A
I_{RMSM}	Maximum RMS Current at Rectifier Output @ $T_C=80^\circ\text{C}$	20	A
I_{FSM}	Surge Forward Current $V_R=0\text{V}, t_p=10\text{ms}, T_j=45^\circ\text{C}$	150	A
I^2t	I^2t -value, $V_R=0\text{V}, t_p=10\text{ms}, T_j=45^\circ\text{C}$	110	A^2s

Characteristics Values

Symbol	Parameter	Test Conditions	Min.	Typ.	Max.	Units
V_F	Diode Forward Voltage	$I_F=7\text{A}$ $T_j=150^\circ\text{C}$			1.01	V
I_R	Reverse Current	$T_j=150^\circ\text{C}, V_R=1600\text{V}$			0.7	mA

IGBT-brake-chopper $T_C=25^\circ\text{C}$ unless otherwise noted**Maximum Rated Values**

Symbol	Description	GD10PIK60C5S	Units
V_{CES}	Collector-Emitter Voltage @ $T_j=25^\circ\text{C}$	600	V
V_{GES}	Gate-Emitter Voltage @ $T_j=25^\circ\text{C}$	± 20	V
I_C	Collector Current @ $T_C=25^\circ\text{C}$ @ $T_C=80^\circ\text{C}$	20 10	A
I_{CM}	Pulsed Collector Current $t_p=1\text{ms}$	20	A
P_{tot}	Total Power Dissipation @ $T_j=150^\circ\text{C}$	82	W
T_{SC}	Short Circuit Withstand Time @ $T_j=150^\circ\text{C}$	10	μs

Off Characteristics

Symbol	Parameter	Test Conditions	Min.	Typ.	Max.	Units
$V_{(BR)CES}$	Collector-Emitter Breakdown Voltage	$T_j=25^\circ\text{C}$	600			V
I_{CES}	Collector Cut-Off Current	$V_{CE}=V_{CES}, V_{GE}=0\text{V},$ $T_j=25^\circ\text{C}$			5.0	mA
I_{GES}	Gate-Emitter Leakage Current	$V_{GE}=V_{GES}, V_{CE}=0\text{V},$ $T_j=25^\circ\text{C}$			400	nA

On Characteristics

Symbol	Parameter	Test Conditions	Min.	Typ.	Max.	Units
$V_{GE(th)}$	Gate-Emitter Threshold Voltage	$I_C=250\mu A, V_{CE}=V_{GE}, T_J=25^\circ C$	3.5	4.5	5.5	V
$V_{CE(sat)}$	Collector to Emitter Saturation Voltage	$I_C=10A, V_{GE}=15V, T_J=25^\circ C$		1.80	2.25	V
		$I_C=10A, V_{GE}=15V, T_J=150^\circ C$		2.20		

Switching Characteristics

Symbol	Parameter	Test Conditions	Min.	Typ.	Max.	Units	
Q_G	Gate charge	$V_{CC}=400V, I_C=10A, V_{GE}=15V$		38		nC	
$t_{d(on)}$	Turn-On Delay Time	$V_{CC}=400V, I_C=10A, R_G=47\Omega, V_{GE}=15V, T_J=25^\circ C$		30		ns	
t_r	Rise Time			20		ns	
$t_{d(off)}$	Turn-Off Delay Time			230		ns	
t_f	Fall Time			23		ns	
E_{on}	Turn-On Switching Loss				0.14		mJ
E_{off}	Turn-Off Switching Loss				0.25		mJ
$t_{d(on)}$	Turn-On Delay Time	$V_{CC}=400V, I_C=10A, R_G=47\Omega, V_{GE}=15V, T_J=150^\circ C$		30		ns	
t_r	Rise Time			20		ns	
$t_{d(off)}$	Turn-Off Delay Time			250		ns	
t_f	Fall Time			26		ns	
E_{on}	Turn-On Switching Loss				0.23		mJ
E_{off}	Turn-Off Switching Loss				0.35		mJ
C_{ies}	Input Capacitance	$V_{CE}=30V, f=1Mhz, V_{GE}=0V$		620		pF	
C_{oes}	Output Capacitance			62		pF	
C_{res}	Reverse Transfer Capacitance			22		pF	
I_{SC}	SC Data	$T_P \leq 10\mu s, V_{GE}=15V, T_J=125^\circ C, V_{CC}=360V, V_{CEM} \leq 600V$		TBD		A	

DIODE-brake-chopper $T_C=25^\circ\text{C}$ unless otherwise noted**Maximum Rated Values**

Symbol	Description	GD10PIK60C5S	Units
V_{RRM}	Repetitive Peak Reverse Voltage @ $T_J=25^\circ\text{C}$	600	V
I_F	DC Forward Current @ $T_C=80^\circ\text{C}$	10	A
I_{FRM}	Repetitive Peak Forward Current $t_p=1\text{ms}$	20	A

Characteristics Values

Symbol	Parameter	Test Conditions	Min.	Typ.	Max.	Units
V_F	Diode Forward Voltage	$I_F=10\text{A}, V_{GE}=0\text{V}$	$T_J=25^\circ\text{C}$	1.20	1.60	V
			$T_J=125^\circ\text{C}$	1.25		
t_r	Reverse Recovery Time	$V_R=600\text{V},$ $I_F=10\text{A},$ $R_G=47\Omega,$ $V_{GE}=-15\text{V}$	$T_J=25^\circ\text{C}$	/		ns
			$T_J=125^\circ\text{C}$	90		
I_{RM}	Peak Reverse Recovery Current	$I_F=10\text{A},$ $R_G=47\Omega,$ $V_{GE}=-15\text{V}$	$T_J=25^\circ\text{C}$	/		A
			$T_J=125^\circ\text{C}$	19		
E_{rec}	Reverse Recovery Energy	$V_{GE}=-15\text{V}$	$T_J=25^\circ\text{C}$	/		mJ
			$T_J=125^\circ\text{C}$	0.25		

Electrical Characteristics of NTC $T_C=25^\circ\text{C}$ unless otherwise noted

Symbol	Parameter	Test Conditions	Min.	Typ.	Max.	Units
R_{25}	Rated Resistance			5.0		k Ω
$\Delta R/R$	Deviation of R_{100}	$T_C=100^\circ\text{C}, R_{100}=493.3\Omega$	-5		5	%
P_{25}	Power Dissipation				20.0	mW
$B_{25/50}$	B-value	$R_2=R_{25}\exp[B_{25/50}(1/T_2-1/(298.15\text{K}))]$		3375		K

IGBT Module

Symbol	Parameter	Min.	Typ.	Max.	Units
V _{ISO}	Isolation Voltage RMS, f=50Hz, t=1min		2500		V
L _{CE}	Stray Inductance		60		nH
R _{CC'+EE'}	Module Lead Resistance, Terminal to Chip @ T _C =25°C		4.00		mΩ
R _{θJC}	Junction-to-Case (per IGBT-inverter)			1.53	K/W
	Junction-to-Case (per DIODE-inverter)			2.66	
	Junction-to-Case (per DIODE-rectifier)			1.91	
	Junction-to-Case (per IGBT-brake-chopper)			1.53	
	Junction-to-Case (per DIODE-brake-chopper)			2.66	
R _{θCS}	Case-to-Sink (Conductive grease applied)		0.02		K/W
T _j	Maximum Junction Temperature			150	°C
T _{STG}	Storage Temperature Range	-40		125	°C
Mounting Torque	Mounting Screw:M5	3.0		6.0	N.m
G	Weight of Module		200		g

Equivalent Circuit Schematic

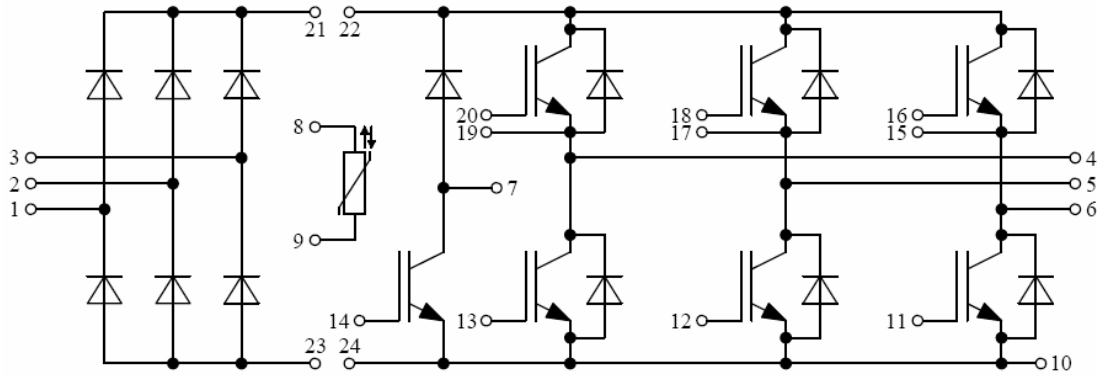

Package Dimension

Dimensions in Millimeters

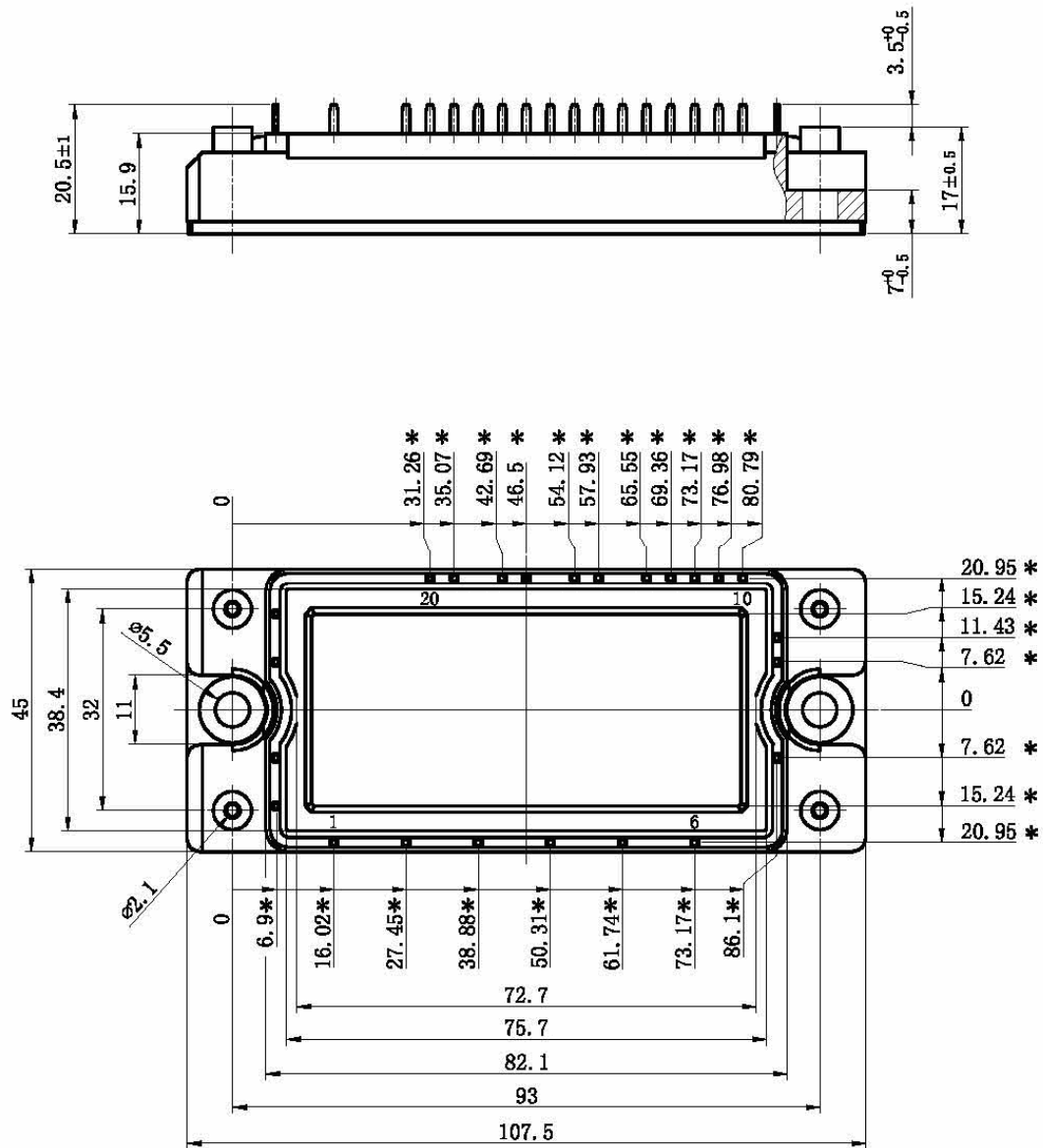

Terms and Conditions of Usage

The data contained in this product datasheet is exclusively intended for technically trained staff. you and your technical departments will have to evaluate the suitability of the product for the intended application and the completeness of the product data with respect to such application.

This product data sheet is describing the characteristics of this product for which a warranty is granted. Any such warranty is granted exclusively pursuant the terms and conditions of the supply agreement. There will be no guarantee of any kind for the product and its characteristics.

Should you require product information in excess of the data given in this product data sheet or which concerns the specific application of our product, please contact the sales office, which is responsible for you (see www.powersemi.cc), For those that are specifically interested we may provide application notes.

Due to technical requirements our product may contain dangerous substances. For information on the types in question please contact the sales office, which is responsible for you.

Should you intend to use the Product in aviation applications, in health or live endangering or life support applications, please notify.

If and to the extent necessary, please forward equivalent notices to your customers.
Changes of this product data sheet are reserved.